

Product Specification

Check Sieving

Slimline Easilift Range

A sack tip sieve station capable of processing up to 25kg worth of product at one time.

Used together with either the 550 or 950 Slimline sieve, the Easilift range features an inclined sack rest table for ergonomic bag tipping and a Powerlift dust hood to minimise heavy lifting. Up to 25kg of product can be dispensed at a time for check screening into containers, static weigh bins, convey systems, or mixers.



sm siev
master
by farleygreene

Features & Benefits

- Powerlift hood, no heavy lifting or awkward sleeve connections
- Self-sealing silicone diaphragm that provides a dust tight interface
- Hygienic open section support frame on standard models
- Conforms to CE, UKCA, FDA, EC 1935/2004 and ANIA regulations
- Rated to ATEX zone 21 II 2D
- Dust and waterproof to at least IP65
- Easy-Clean hygienic design, no crevices
- No tool, quick change screens
- Quick release direct earthing kit included as standard
- All stainless-steel body and contact parts
- Inclined sack rest table to ensure all powders are captured for screening
- Low maintenance/running costs – tool free disassembly & minimal servicing

Industries:



Food & Drink



Pharma



Chemical



Additive

Product Options*

Ultrasonic upgrade - eliminates mesh blinding.



Ultra-Hygienic Version - the Easilift Ultra, additional hygiene features.



Underscreen magnet - with optional silicone covers.



Local Dust Extraction (electric) - with reverse air jet filter cleaning.



Dust Hood Door - vertical powerlift via 304SS gas struts.



Connection to vacuum transfer system - 50mm vacuum type outlet connection.



Side outlet - 100mm diameter downturn outlet (550 model only).



Sieve unit rated to ATEX zone 21 II 2D, dust hood and frame to ATEX zone 22 II 3D.



*More options available on request

Typical Materials

- Sacks and containers of dry powdered / granular food, pharmaceutical, & chemical materials.

Finishes available

- Dressing of External Welds - gallery & funnel.
- External Dull Polish to <0.8 Ra
- VivateQ® / Sublimotion Finish
- Pharma Polish - to <0.25 Ra internally and externally.

Certified Technology



THIRD ANGLE PROJECTION

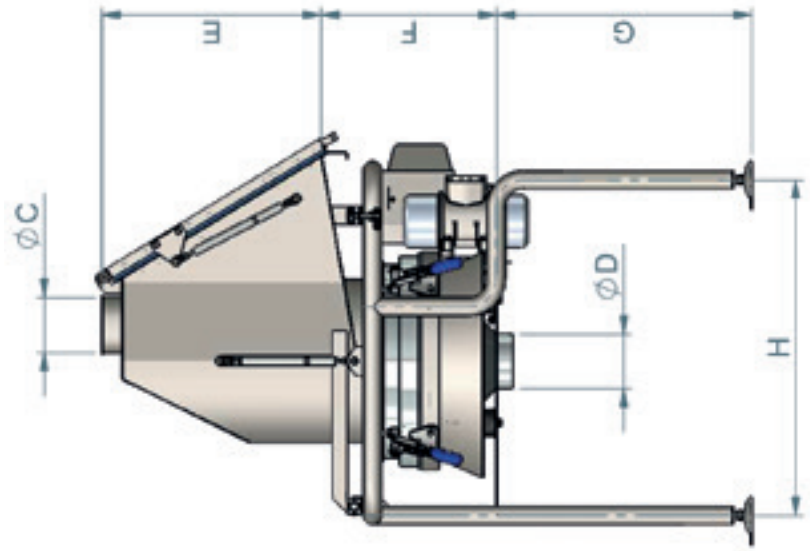
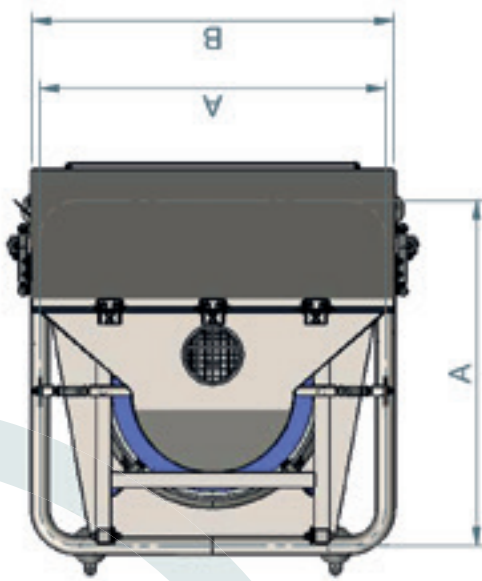

SM EASILIFT 550 & 950

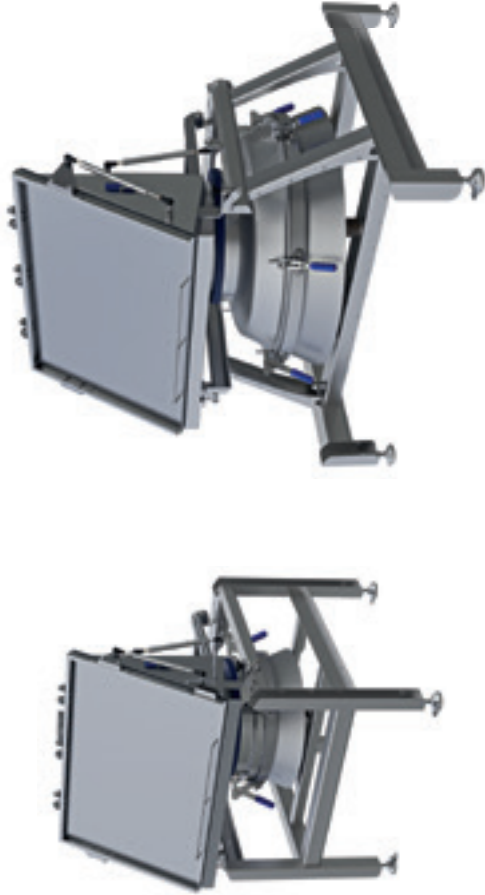

DIMENSION	SM-ESL-550 (mm)	SM-ESL-950 (mm)
A	1050	1300
B	1000	1250
C	150	150
D	150 - 300*	150 - 400*
E	610	610
F	510	632
G	300 - 1000*	300 - 1000*
H	900	1100

Screen diameter = 565mm & 965mm

**For outlet heights over 450/300mm step may be required.

*Available with outlet suitable for connection to vacuum line.

ELECTRICAL	SM-ESL-550	SM-ESL-950
Voltage	110 / 240 / 380-460	110 / 240 / 380-460
Frequency	50 / 60 hz	50 / 60 hz
Power	0.35 kw	0.9 kw
Phase	1 / 3	1 / 3
ATEX	Yes 	Yes 