

Product Specification

Small Batch Sieving

200-S

A 200mm diameter sieve designed to sit directly on top of a container.

A circular frame supports the sieve so that ingredients can be tipped into the top and check sieved into a container below.

The Sievmaster 200-S can be used for straining liquids as well as dry ingredients. It comes with three interchangeable mesh inserts for coarse, medium & fine/liquid applications.



Features & Benefits

- Easy-Clean hygienic design, no crevices
- Conforms to CE, UKCA, FDA, EC 1935/2004 and ANIA regulations
- No tool, quick change screens
- Wet or dry applications
- Dust and waterproof to at least IP65
- Open top hopper for ease of dispensing
- All stainless steel body and contact parts
- Low maintenance/running costs – tool free disassembly & minimal servicing

Industries:



Food & Drink



Pharma



Chemical



Additive

Product Options*

Top Dust Cover - removable top cover with gasket and clamp.



Top Cone Meshed - ET5145 adhesive.



Bench Mounting Kit - allows the sieve to be freestanding.



Collection Bin - wheels available.



*More options available on request

Typical Materials

- Most food, beverage & chemical powders and granular products
- Liquid separation

Finishes available

- Internal Dull Polish to <0.8 Ra

Certified Technology



1

2

3

4

5

6

THIRD ANGLE PROJECTION



SM 200-S ARTISAN SIEVE

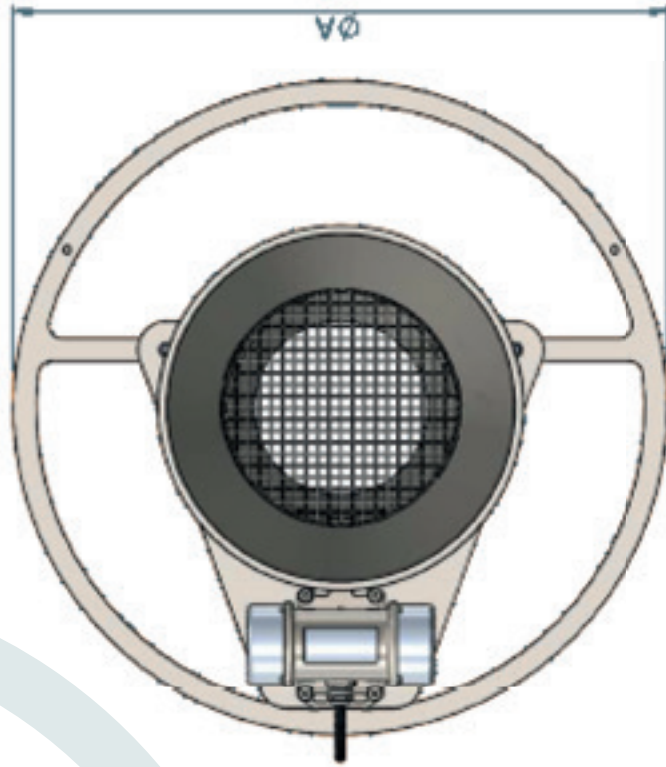

DIMENSION	SM200-S (mm)
A	565
B	300
C	250
D	150

Screen diameter = 200mm

Bench mount legs give outlet height @ 355mm from ground

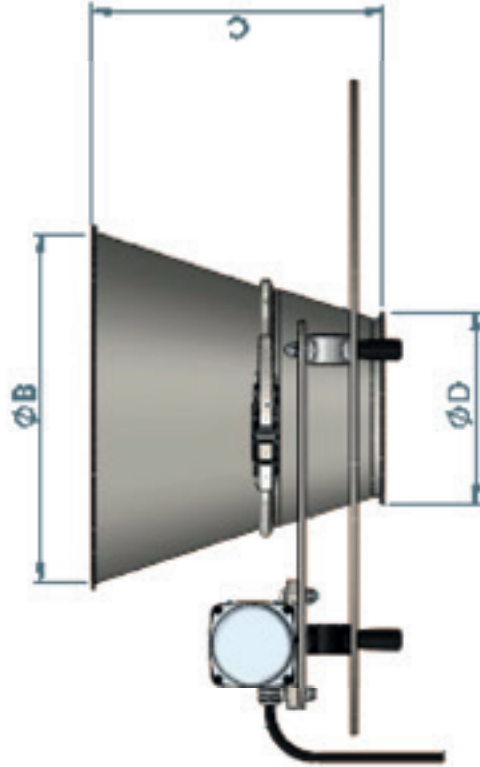

ELECTRICAL	SM200-S
Voltage	110 / 240
Frequency	50 / 60 hz
Power	45 w
Phase	1
ATEX	No