

Product Specification

Check Sieving

700-ST

The 700-ST combines the highest degree of control with the most hygienic design elements.

Fully stainless steel contact parts and external components mean it can be used in the most demanding environments, whilst tool-free, quick change mesh screens minimise downtime between batches.

It is available with a mobile base assembly as standard or can be supplied with adjustable bolt-down feet, and can be upgraded to fully stainless steel construction throughout.



sm sievmaster
by farleygreene

Features & Benefits

- High throughput for a low footprint machine
- A fully sealed system
- Wet or dry applications
- Easy-Clean, hygienic design
- Conforms to CE, UKCA, FDA, EC 1935/2004 and ANIA regulations
- Rated ATEX zone 22 II 3D
- No tool quick change screens
- All stainless steel body with 316 contact parts
- Dust and waterproof to at least IP65
- Low maintenance/running costs - tool free disassembly & minimal servicing
- A mobile unit that can be used under big bag or bulk container discharging systems, or in production lines at Critical Control Points

Industries:



Food & Drink



Pharma



Chemical



Additive

Product Options*

Mesh Deblinding -
Ultrasonic.



Sack/bag Entry with safety Hex Grid - Side wall cut away for bag loading into open unit.



Enclosed Top Cover -
Removable top cover with 150mm diameter central inlet.



Weirflow Type Inlet - For increased product infeed flow control.



Underscreen Magnet Assy -
7000, 9000, or 11000 gauss.



Upgrade to ATEX zone 21 II 2D internal and ATEX zone 22 II 3D external.



*More options available on request

Typical Materials

- Most food, pharmaceutical, & chemical powders and granular products
- Liquid separation

Finishes available

- Dressing of External Welds
- Internal & External Dull Polish to <0.8 Ra
- VivateQ® / Sublimation Finish
- Pharma Polish - to <0.25 Ra internally and externally.

Certified Technology



1

2

3

4

5

6

THIRD ANGLE PROJECTION

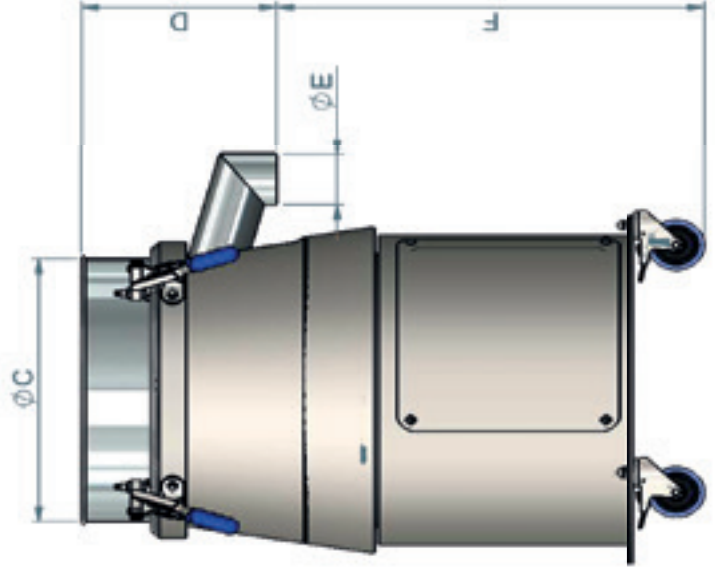
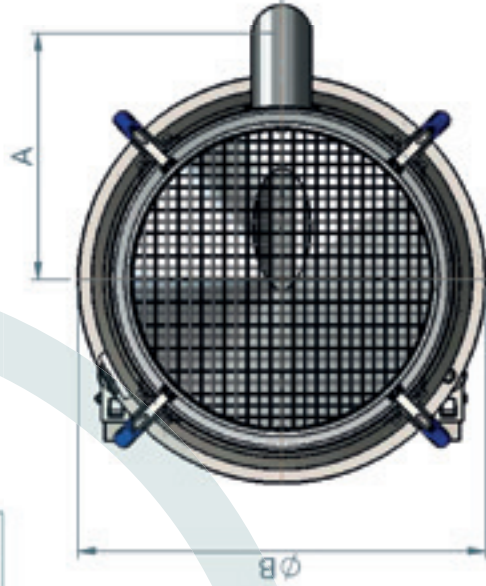

SM 700-ST



DIMENSION	SM700-ST (mm)
A	430
B	630
C	530
D	350*
E	100
F	770

Screen diameter = 565mm
 Enclosed top & oversize outlet available (refer to SM550-FF DRG)

*For underscreen magnet assy add 50mm to 'D' DIM
 Allow min. 50mm for flexible connections to inlet/outlet

ELECTRICAL	SM700-ST
Voltage	110 / 240 / 380-460
Frequency	50 / 60 hz
Power	0.55 kw
Phase	1 / 3
ATEX	Yes 