

Product Specification

Check Sieving

E-400 Range

A modular check sieve with a sack tip or grading configuration.

The Sievmaster E-400 is comprised of a modular sieve stack built on a mobile frame; each stack is designed to be flexible enough to suit requirements such as grading and/or sack tipping.

Primarily aimed at the food, chemicals, and artisan markets, these mobile units can be adapted to meet requirements as they change, or fit different points in a process.

Their modular design means they can be easily adapted by the user for check screening, grade sieving (E-400-GRV), or low volume sack tipping (E-400-STV).

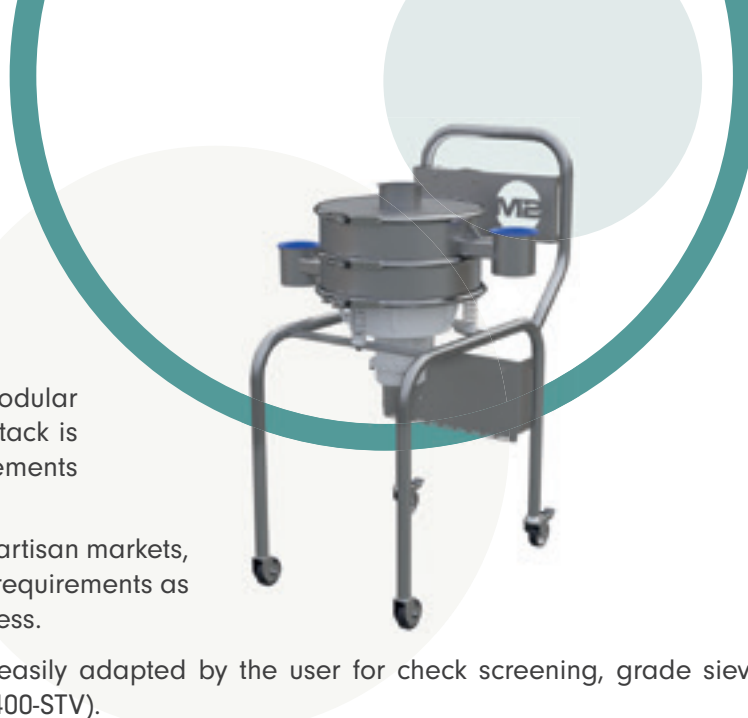

sm sievmaster
by farleygreene

Features & Benefits

- The unit can utilise the STV components to become a sack tipping unit or GRV components to become a grading unit with no other modifications
- Sieve directly into tote bins, drums, or bags
- Bag cut out and internal sack rest grid (STV components)
- Conforms to CE, UKCA, FDA, EC 1935/2004 and ANIA regulations
- Dust and waterproof to at least IP65
- No tool, quick change screens
- Wet or dry applications
- All stainless steel contact parts
- Mobile support frame
- Easy-Clean design, no crevices
- Low maintenance / running costs – tool free disassembly & minimal servicing

Industries:



Food & Drink



Pharma



Chemical



Additive

Product Options*

Ultrasonic upgrade - eliminates mesh blinding.



Addition of underscreen magnet assy- 9000 gauss.



Continuous processing of 2 fractions - Oversize / fines.



Mesh debinding - Mechanical.



Continuous processing of 3 fractions - Oversize / cut 1 / fines.



Upgrade to ATEX zone 22 II 3D available



*More options available on request

Typical Materials

- Most food, pharmaceutical, & chemical powders and granular products

Finishes available

- Internal Surfaces Dull Polish to <0.8 Ra

Certified Technology



1

2

3

4

5

6

THIRD ANGLE PROJECTION

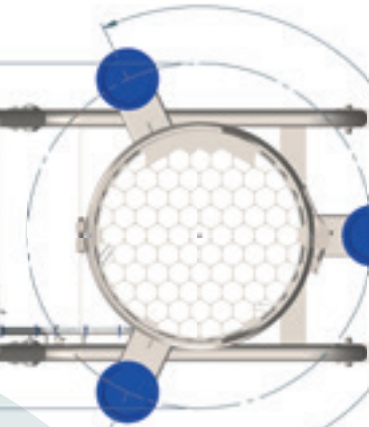
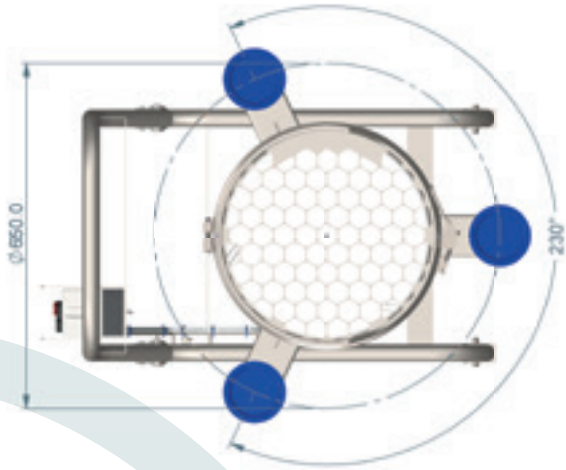

SM E-400-STV

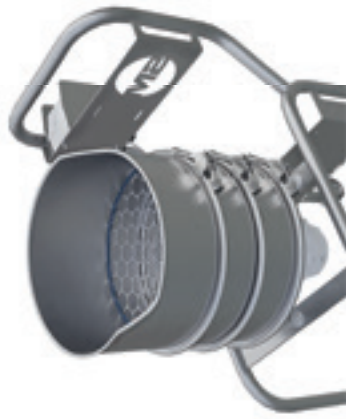
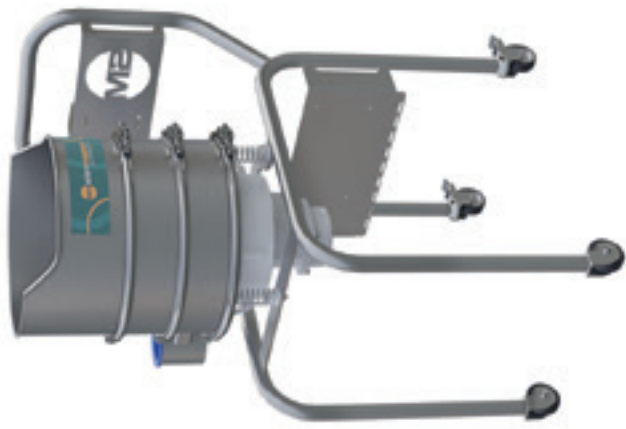

A

B

C

D

DIMENSION (mm)	A	B	C	D
SM E-400-STV	735	840	1110	400

For underscreen magnet, add 55 to dimension

ELECTRICAL	SM E-400
Voltage	110-240 / 380-460
Frequency	50 / 60 hz
Power	3 Phase 0.17kW / 0.17kW 1 Phase 0.21kW / 0.23kW
Phase	1 / 3
ATEX	YES 

1

THIRD ANGLE PROJECTION



2

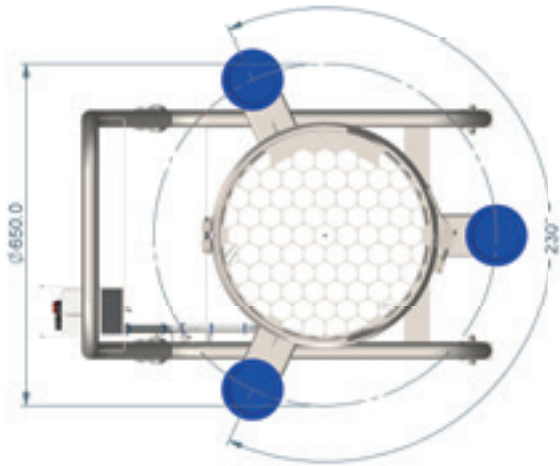

3

4

5

6

SM E-400-GRV

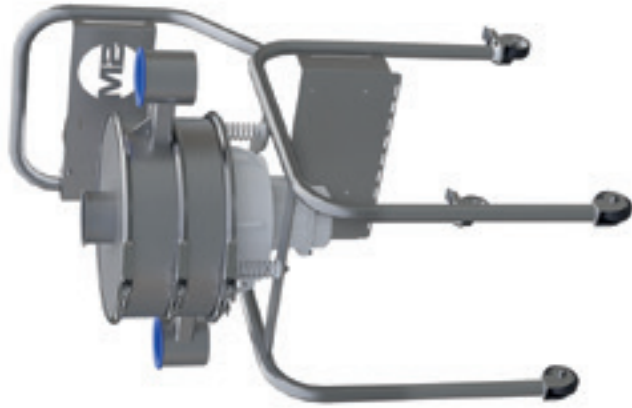

A

B

C

D

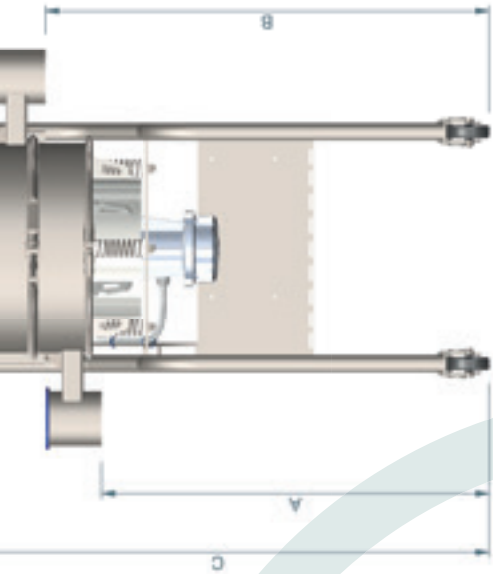

DIMENSION (mm)	A	B	C	D
SM E-400-GRV	735	840	1028	100

For underscreen magnet, add 55 to dimension

ELECTRICAL	SM E-400
Voltage	110-240 / 380-460
Frequency	50 / 60 hz
Power	3 Phase 0.17kW / 0.17kW
Phase	1 / 3
ATEX	YES 