

NEW PRODUCT

Product Specification

Centrifugal Sieving

Rota Range

Where high volume bulk check screening is required, the Rota Range provides non-vibratory centrifugal sifting.

Rota sifters use a set of revolving paddles to push product outwards against the mesh cylinder, forcing fine product through and continuously ejecting coarse product via a separate outlet.

Rotas are dust-tight and can be fixed into place within your process line. The internal mesh screen assembly and sieving paddle components are fully removable without the need for any tools. The mesh can also be fully inspected across its full circumference and length whilst still in place inside the machine.



SM siev
master
by farleygreene

Features & Benefits

- Available in 3 sizes (from smallest to largest): 90-C single basket, 180-C single basket, and 360-C twin basket variants
- Quick release side door toggle clamps for quick inspection
- Enhanced sealing profile on all doors
- Standard units can be used for gravity system, vacuum to -0.4bar and pressure to +0.8bar with a small safety upgrade**
- Available with stainless or nylon woven mesh, wedgewire and perforated mesh screens
- All stainless steel metal contact parts
- High volume bulk sieving for wet or dry applications
- For use under big bag or bulk container discharging systems within production lines
- Can be used with any type of mechanical or pneumatic conveyor systems, with correct options
- Deagglomeration of compacted material in one action
- Cantilever shaft design to provide easy access to mesh screen & minimal servicing

**if converting from gravity to +/- pressure please contact us for your free upgrade kit.

Industries:



Food & Drink



Pharma



Chemical



Additive

Product Options*

Wedgewire mesh basket - comes with blue metal detectable flange gasket.

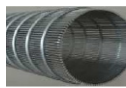

Support frame - static or mobile (open section hygiene design).



Perforated mesh basket.



Suitable for vacuum or pressure applications - see above.

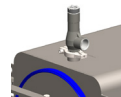

316 contact parts available.



Overflow collection barrel - 10 or 20 litre.



Inlet transition piece - available on all models.

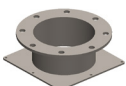

Overflow outlet butterfly valve - for "no spill" overflow barrel change over.



Fines transition piece - available on all models.



Deagglomeration of product (lump breaking)

dedicated lump breaking machines are available for compacted or solid material breakdown.



Easy-Clean magnet assy to fines - magnet drawer.

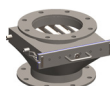

*More options available on request

Typical Materials

- Almost any powder or granulated material used in the food, beverage, and chemical industries.

Finishes available

- Dressing of External Welds
- Internal Dull Polish to <0.8 Ra
- VivateQ® / Sublimation Finish
- Pharma Polish - to <0.25 Ra internally and externally.

Certified Technology



1

2

3

4

5

6

THIRD ANGLE PROJECTION

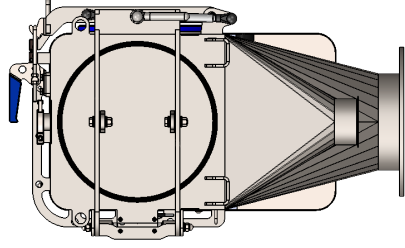
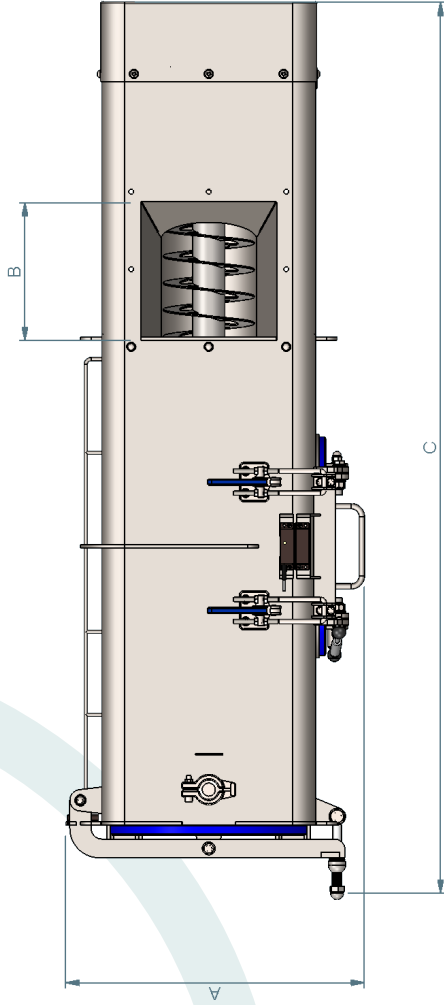

SM ROTA 180

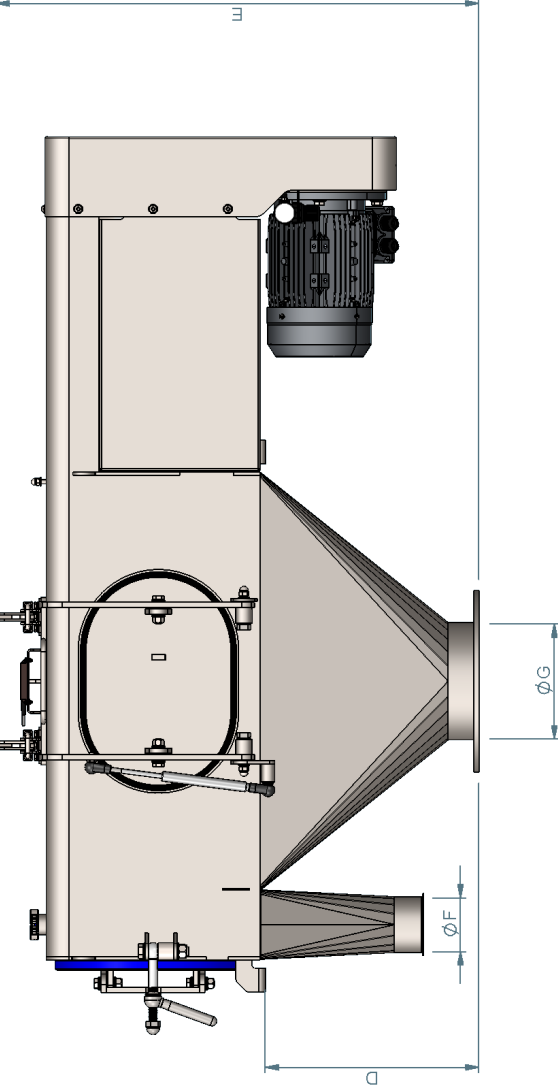

DIMENSION	SM-ROTA-180 (mm)
A	560
B	260
C	1670
D	400
E	905
F	Ø100
G	Ø 215

SCREEN SIZE = Ø195MM X 790MM LONG
MOBILE OR STATIC FRAMES AVAILABLE
SUITABLE FOR USE WITH VACUUM OR PRESSURE LINES

ELECTRICAL	SM-ROTA-180
Voltage	240 / 380-460
Frequency	50 / 60 hz
Power	2.2 kW
Phase	3
ATEX	Yes 

For more information on the other machines in the range, please enquire.